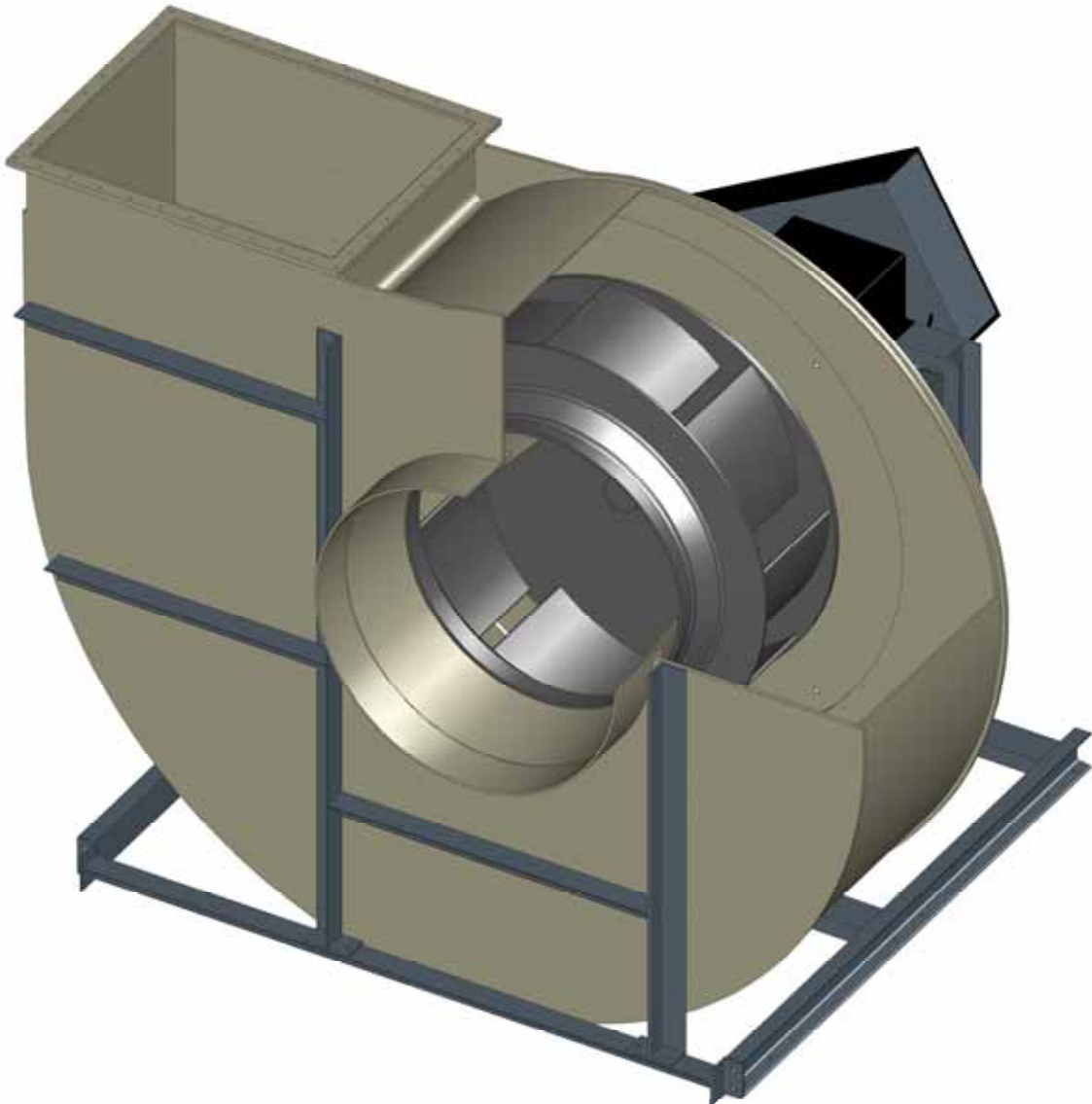

**High efficiency medium pressure – Plastic industrial fan**

**Agent:** COLASIT AG – Faulenbachweg 63 – CH-3700 Spiez  
Phone: +41 33 655 61 61 – Fax: +41 33 654 81 61  
e-mail: info@colasit.ch

COLASIT Order No.: \_\_\_\_\_

Fan type: \_\_\_\_\_

Year of manufacture: \_\_\_\_\_





**TD-000 802-E**

## Preface

This operating manual is the driver's license for operation of this COLASIT fan. It is the main source of information and also the safety guideline. It deserves your full attention - please read it carefully.

The contents of this operating manual are subject to change without notice in order to take technical progress into account.

The manual contains icons that appear in the margin and indicate special dangers and important instructions.

	Very important note
	Universally applicable warnings which concern your personal safety.
	Indicates electrical dangers.
	Indicates process control dangers.

The entire operating manual consists of 3 parts:

Part 1: General

Part 2: Components

Part 3: Certificates

## Table of contents

Part 1: General .....	4
1 General .....	4
1.1 Definition .....	4
1.2 Production of COLASIT-fans .....	4
1.3 Warranty .....	4
1.4 Safety review .....	5
1.5 Personnel qualifications .....	5
1.6 Possible emergencies .....	5
1.7 Safety officer (SO) .....	5
1.8 General risk matrix .....	6
1.9 EC conformity of the COLASIT fan .....	7
1.10 Restrictions when commissioning .....	7
1.11 General operation conditions .....	7
2 Shipping, unpacking, inspection, storage .....	8
3 Installation, configuration .....	8
4 Commissioning, initial startup, test run .....	9
4.1 Inspection of the installation and settings .....	9
4.2 Drive .....	9
4.3 Electrical installations, EMERGENCY STOP .....	9
5 Operation .....	10
5.1 Safety instructions .....	10
5.2 Putting out of operation .....	10
6 Maintenance, repair, cleaning .....	10
6.1 Preparation .....	10
6.2 Performance .....	11
7 Spare parts .....	12
8 Operating instructions .....	12
9 Logbook .....	13
10 Disposal .....	13
11 Troubleshooting .....	13
12 Retrofittable original accessories .....	14
13 Fan identification .....	14
Part 2: Units .....	14
14 Design and function of the CMHV 900-1250 .....	14
15 Dimensional drawings .....	15
15.1 Dimensions of the CMHV 900-1250 with direct drive .....	15
15.2 Dimensions of the CMHV 900-1250 with V-belt drive .....	16
16 Assembly instructions .....	17
16.1 Assembly instructions CMHV 900–1250 with direct drive .....	17
16.2 Assembly instructions for CMHV 900–1250 with V-belt drive .....	18
17 Spare parts lists .....	20
17.1 Spare parts list for CMHV 900-1250 with direct drive .....	20
17.2 Spare parts list for CMHV 900-1250 with V-belt drive .....	21
Part 3: Certification .....	22
18 Certifications .....	22
18.1 CE Manufacturer's declaration .....	22
18.2 Further certificates .....	23

# Part 1: General

## 1 General

### OBLIGATIONS

Prior to any work done on or with the fan, we place you under an obligation to read this operating manual and any further contractors' operating instructions carefully and through to the end. Should anything not be clear, please get in touch with us immediately. Do not put the fan into operation as long as uncertainties exist. As soon as you start up the fan you confirm that you have read and understood the operating manual.



After acquainting yourself with the fan and its operational performance together with your production processes, we recommend that you make a note of the different modes of operation in a "process instruction".

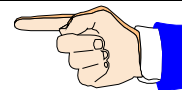

Together with this operating manual, any acceptance documents, works acceptance certificates and the EC Declaration of Conformity, the process instruction forms part of the complete system documentation.

**For the fan, a separate risk analysis was conducted as a prerequisite for writing this operating manual. Risks were evaluated and any remaining residual risks are pointed out in this operating manual.**

When extracting aggressive gases, it is imperative to review the suitability of the materials:

- Once the principal or the operator has notified us of the gas mix and the maximum operating temperature, the suitability and any applicable restrictions will be confirmed in the data sheet of COLASIT AG.
- **In the absence of a written notification with regard to the extracted medium by the principal, the operator is responsible without limitation for assessing the suitability for the operation of the ventilator.**

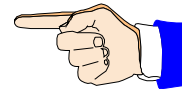

### 1.1 Definition

The term "COLASIT fan" stands for a Swiss high-quality product and contains all the components and individual parts as specified in the purchase order or in the material parts list, which, when assembled, form a functional unit.

### 1.2 Production of COLASIT-fans

The fan was manufactured using modern production methods and was extensively tested both during manufacture and as a finished product by the COLASIT quality assurance system. The methods and processes used in production and monitoring correspond to the state of the art. The personnel entrusted with production of the fan have the appropriate skills and possess valid qualifications. All fans with engine are subjected to a successful test run at the manufacturer's production facilities.

### 1.3 Warranty

Warranty ends on the date stated in the general terms of sale and delivery. Warranty is limited to the delivery of spare parts or the repair of defective parts at the manufacturer's factory. Any further claims or the replacement of non-repairable or wear parts are excluded.

We guarantee the availability of spare parts identical in construction to the original over a period of 10 years effective from the date of delivery.

COLASIT only guarantees the durability of materials on condition that technological data was available before production.  
Any change in the conditions of use is only permissible after approval by COLASIT; otherwise this will entail loss of warranty.  
Any changes or repair work during the warranty period may only be made by our fitters or with our written consent.  
We refer to the limitation of warranty noted in the “Motor“-section in the case where a frequency converter supplied by a third party is fitted.

The fan must be deployed and used in accordance with the conditions mentioned in this operating manual. Only in this way can its function be guaranteed and dangers to persons and material be excluded during operation. We accept no liability nor guarantee any claims for damages arising from nonobservance of this manual or from inappropriate operation

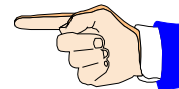

## **1.4 Safety review**

After installing the fan, we recommend the operator conducts a review of the entire operational environment. In this way it can be guaranteed that neither the fan will suffer damage nor that the fan will cause any damage.

## **1.5 Personnel qualifications**

The fan may only be put into operation, handled, operated, maintained and cleaned by trained personnel who are authorised (and competent) to carry out such work.  
The personnel must possess the appropriate skills needed to operate the fan and be familiar with the effects of the reactions caused by the fan.  
The personnel qualified to operate the fan must be able to react adequately and correctly in case of a fault or an emergency.

## **1.6 Possible emergencies**

An emergency may result from the bursting or melting of plastic components as a result of mechanical damage or chemical and thermal influences. In this case, parts may fly off or vapour may be produced that may be hot, corrosive, poisonous, irritating or inflammable (e.g. hydrochloric acid vapour occurring from burning PVC).  
There may be a danger of fire under certain circumstances.  
For the choice of the correct fire-extinguishing devices and the positioning of the firefighting equipment, please follow the recommendations of your local fire station.

## **1.7 Safety officer (SO)**

The function of the safety officer or his representative is defined in the operating company's organisational chart. The name of the person must be known to all personnel who are responsible for the fan.  
The operating company defines his competencies and his area of responsibility.  
The safety officer approves the fan for operation.

## 1.8 General risk matrix

### Operation

The safety regulations prevailing at the operator's location are mandatory and must be observed at all times. Before making an intervention, the process must be stopped, i.e. all mechanical movement must be stopped and it must be ensured that no automatic motion can occur.



### Missing safety devices

If the fan is equipped with safety devices, they may neither be modified nor removed. Further safety devices of suitable design must be fitted by the operator and are subject to his control.



### Disregard of safety precautions

Please implement all safety measures so that the fan, together with its associated equipment, can operate properly and any danger to persons, materials and products can be excluded.



### Putting the fan out of operation

In the case of damage to or failure of safety devices, the fan must be stopped and put out of operation. It may only be put into operation again when the safety devices are fully functional again.



### Overpressure

If the fan is operated in overpressure conditions with normal seals, there is a danger of gas escaping.  
For operation in overpressure conditions, special seals must be fitted.



### Electricity

When any work is carried out on the fan, the electric motor must be deenergised and secured to prevent it from switching on. The main power switch must be secured against operation by third parties using a lockable device (e.g. padlock) by the persons working on the fan. **Full disconnection of the motor is only permissible in case of complete removal!**

The safety regulations for work on electrical equipment prevailing at the place of operation must be observed at all times and be available for reference at the place of operation.

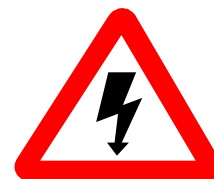

### Electrostatic charge

Media flowing through the plastic components may cause the buildup of electrostatic charge. These are harmless to persons who do not react to electrical impulses in the body



### Unsuitable materials

Through the use of inappropriate materials, the fan and/or parts may be damaged or become non-functional. Please always use original spare parts and contact the manufacturer in any case of doubt.



## Dangerous media

Depending on the mode of operation, fan parts may come in contact with dangerous media.

Work on the fan or carrying out maintenance work is not allowed during operation. Before carrying out any work, any dangerous media must be removed from the system and, when required, must be neutralized and secured in such a way that an inflow of dangerous media is prevented.



## 1.9 EC conformity of the COLASIT fan

The fan was designed, built and tested to Directive 2006/42 EC.

In addition to this EC Directive and EN standards which have the equivalent status of a Swiss standard, Swiss safety and accident-prevention regulations have also been taken into account.

An EC Declaration of Conformity in terms of the EC guidelines 2006/42 EC on machines will be issued along with the fan.

## 1.10 Restrictions when commissioning

We stipulate that putting into operation is prohibited as long as the fan, including all parts belonging to it or equipment connected to it, has not been installed and checked out and until the operating manual has been read completely before commissioning.



We stipulate that the fan may only be put into operation when the safety inspector has given his approval. He is obliged to record this approval in a protocol.

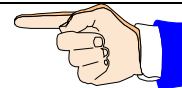

The disregard of these stipulations constitutes negligence.

## 1.11 General operation conditions

The permissible operating conditions are indicated on the manufacturer's plate.

The fan is not suitable for the transport of solids in the air flow. This operating mode will lead to the destruction of the fan.

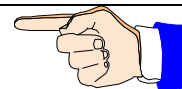

The ducts on the intake and delivery sides must always be open. A closed duct will lead to a rise in temperature which could cause the destruction of the fan.

The minimum air speed through the fan is 5 meters per second.

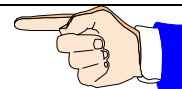

The maximum air speed may not exceed 30 meters per second through the fan.

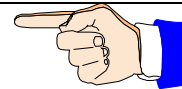

The standard motors are designed for normal operating conditions (ambient temperature +40°C, altitude below 1000 m above sea level, air pressure up to 1050 hPa). In case of any divergence from these conditions, please contact COLASIT.

Compliance with these operating conditions is the responsibility of the operator.

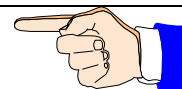

## 2 Shipping, unpacking, inspection, storage

The fan is completely assembled and can be delivered in a closed film wrapping. Please make sure the delivery corresponds to the shipping documents.

Please examine the packaging for external damage and report any damage immediately to the transport company, the supervisor and the manufacturer.

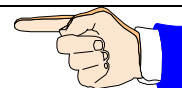

Please handle the fan with care. During transportation, only apply strain on the steel parts. Plastic is sensitive to impact and knocks, especially in the temperature range under +5°C.

When the film is removed, the intake and pressure nozzles are open and unprotected against the intrusion of foreign objects. Therefore, please do not remove the protective film until shortly before final installation.



### Storage

If the fans are not put into operation immediately, store them in a clean dry place where they are protected from impacts, vibrations, and temperature fluctuations and where the air humidity is under 90%.

If these storage conditions are not available, switch the fans on at regular intervals to exclude the risk of condensate forming. Before switching on, unscrew the condensate drain plugs each time and replace them afterwards.

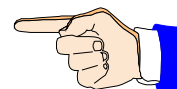

Store the fan in a dry, weather-protected place and cover with a tarpaulin to protect it from dust and soiling.

If stored for over one year, test whether the fan bearings rotate freely before putting into operation.

## 3 Installation, configuration

Before installation, check whether all the locking screws (including the motor screws) are tightened properly. Check the electrical connections if wired at the factory.

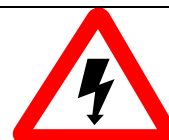

Before installation, check that there are no foreign bodies in the coil or in the intake and pressure connections.

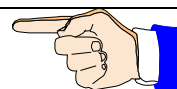

The fan must be installed at a location provided and prepared by the customer and must be secured and connected in such a way that any possible vibration occurring can be absorbed by the vibration dampers supplied by COLASIT.

If no ducting is foreseen on the intake side, the intake connection should be protected by a sturdy protective grating (10mm mesh) to be provided by the customer.

Connection ducting on the pressure side must be routed to prevent the backflow of foreign bodies, rainwater or condensate into the fan. To ensure this, please use the COLASIT condensate drain nozzles.

**Due to the possibility of noise nuisance, we recommend that the fan should not be installed in the immediate vicinity of workplaces.**

## 4 Commissioning, initial startup, test run

The fan should only be put into operation after inspection and approval by the safety officer.

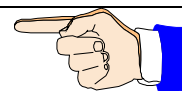

### 4.1 Inspection of the installation and settings

Check list:

Prior to commissioning and initial start-up, it must be guaranteed that

- the fan is installed vibration-free and mechanically secured,
- all components are cleaned both on the inside and the outside and are free from foreign bodies,
- all intake and pressure ducts connections are leak-proofed
- all rotating parts are protected against unintentional contact,
- the electrical connections are installed and their function tested,
- a lockable main control switch is available to which the fan is connected
- the EMERGENCY-STOP equipment is functionally tested,
- the safety inspector has made sure that safety equipment exists,
- the operating personnel is familiar with the operating manual,
- the safety inspector has given his approval for the operation of the installation and that no external persons are present in the plant area

If envisaged by procedural regulations provided by the operator, minutes have to be taken on the commissioning work, including the observance of the check list.

### 4.2 Drive

The fan is driven by an electric motor which is connected to the impeller shaft either directly or via a V-belt.

The motor electrical specifications are indicated on the motor's rating plate or in the motor manufacturer's data sheet.

When speed is controlled by means of a frequency converter, the maximum speed is limited by COLASIT to the value indicated on the manufacturer's rating plate.

If the frequency converter is not supplied by COLASIT, the operator is responsible for compliance with the maximum speed limitation. In this case, COLASIT will not assume any liability for damage that may be attributed to exceeding the maximum speed.

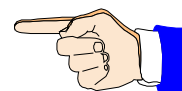

In the case of motor outputs over 3kW, we recommend the use of a soft starter or a star-delta connection.

### 4.3 Electrical installations, EMERGENCY STOP

The electrical installations may only be carried out by an authorised electrician in accordance with the regulations prevailing at the site at which the fan is installed.

To interrupt the power supply, an EMERGENCY STOP switch must be provided. It is advisable to mount this switch in the vicinity of the emergency exit.

Please request confirmation from an in-house electrician that the electrical installations were carried out and tested in accordance with regulations, that all functions were tested (or simulated) and that the rotational direction is correct.

## Warning

Please request confirmation from an in-house electrician that the electrical installations were carried out and tested in accordance with regulations, that all functions were tested (or simulated) and that the rotational direction is correct. Do not turn power on or off without prior warning to persons in the area where the fan is operating. Switching operations must be co-ordinated with other functions in the working area of the fan.

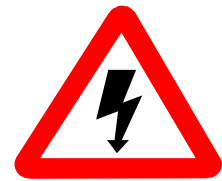

## 5 Operation

### 5.1 Safety instructions

The fan must be operated according to this manual. This will avoid the occurrence of any damage.

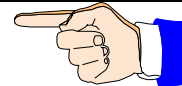

## Supervision

The fan must not be operated unattended as long as it conveys substances whose reactions are unknown or if unexpected reactions are anticipated. If supervision must be withdrawn for operational reasons, this must be reported to the safety officer and the system must be secured in such a way that no unauthorized intervention can be carried out. The safety officer must decide on issues regarding supervision.



### 5.2 Putting out of operation

An internal process instruction must regulate the work to be carried out as well as the preparatory work for putting back into operation (e.g. cleaning).

## 6 Maintenance, repair, cleaning

### 6.1 Preparation

Before any work is carried out on the fan, the fan must be set to its "safety position".

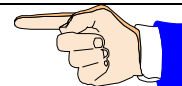

The „safety position“ is defined as follows:

- The drive must be currentless and the main switch secured against switching on,
  - The fan impeller can be manually rotated,
  - Fan must be flushed with fresh air and be condensate-free,
  - Fan must be at room temperature,
  - Personal protective equipment must be available and it must be worn. (Use of protective gloves because of sharp edges, ear protectors if necessary).
  - A sign, e.g. „Under-repair“, must be attached to the system,
  - The safety devices may be removed,
  - The work to be carried out must not be done under time pressure,
  - The general and specific regulations on accident prevention as well as the EKAS guidelines (Switzerland) must be observed,
  - The safety officer must be informed about the nature and course of the work,
- If the intake and delivery ducts of the fan are dismantled for a longer period of time, the openings must be closed off.

## 6.2 Performance

The fan must be maintained in accordance with the Maintenance Plan below. The maintenance work carried out must be noted down in the logbook (see the section on Logbook).

Every week	Every month	Every year
<ul style="list-style-type: none"> <li>• Make a visual inspection of fan for damage, leaks, corrosion and attachment.</li> <li>• Check the smooth running of the fan and electric motor.</li> <li>• Check state and tension of the V-belt and replace if necessary.</li> </ul>	<ul style="list-style-type: none"> <li>• Check the impeller and casing for deposits and clean if necessary.</li> <li>• Check the shaft bearing for smooth running and vibrations. Bearing maintenance -&gt; see chart below for regreasing intervals.</li> <li>• Remove any dust deposits on the fan and motor.</li> <li>• Check the flexible transitions from fan to duct system for leaks and state.</li> <li>• Check the function of the condensate nozzle.</li> <li>• Check the state of the vibration dampers.</li> <li>• Check the state of the hub gasket (if fitted).</li> </ul>	<ul style="list-style-type: none"> <li>• Carry out a thorough cleaning of the entire fan (including impeller).</li> <li>• Check the parts in contact with the conveyed medium for corrosion.</li> <li>• Check the minimum clearance between the impeller and casing (minimum 1% of intake diameter, maximum 20mm).</li> <li>• Measure the vibrations at bearings (KA) or motor (DA). Permitted value acc. to ISO 14694 Class BV-3, 5.1mm/s.</li> <li>• Check the safety devices (e.g. splinter protection or intake grating) for condition and function.</li> <li>• Check the stands for damage and stability.</li> <li>• Check all screw unions for firm seating.</li> </ul>

Normally the bearings are designed for a service life of 40,000 hrs. After this period the bearings must be replaced. The service life of the bearings is reduced when subjected to increased requirements (e.g. high temperature, aggressive ambient air or operation with frequency converter).

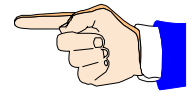

On drives with V-belts, check the tension regularly and monitor the belts closely particularly during the first weeks of operation. This also applies after long periods of downtime. Excessive tension leads to bearing damage, insufficient tension leads to slip, wear and frictional heat.

After replacing a V-belt, check the tension after 1 to 4 hours of operation and retension as necessary. The fan bearings are maintenance-free and the grease filling is designed for about 20,000 hours of operation.

The bearing temperature of 70°C may not be exceeded. In cases of high stress (environment) the grease quantity loses its lubricity over time due to mechanical stresses, ageing and increasing contamination. The bearings must then be greased according to the following table:

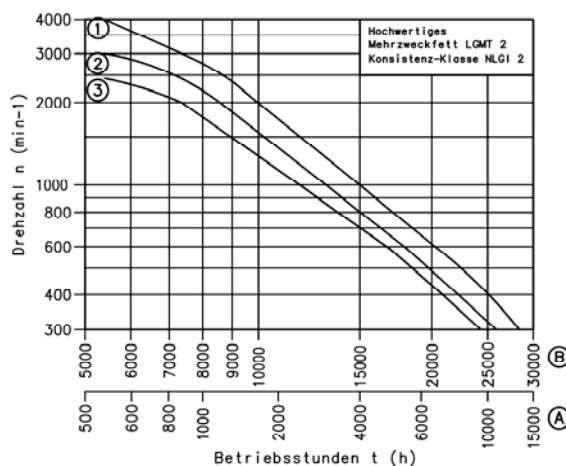

Lager Typ	Kurve Nr.	Skala	Fett g
Y40	1	A	10
Y60	2	A	15
SNL 509	1	B	10
SNL 513	2	B	18
SNL 516	3	B	23
SNL 518	3	B	32

Components which are not intended for repair by the operator must be sent to the manufacturer or agent for repair or replacement (e.g. damaged impeller).

Your agent or COLASIT  
also offers customer services

Manufacturer	<b>COLASIT AG</b>
	P.O. 85
	CH 3700 Spiez / Switzerland
	Tel.: 0041 (0)33 655 61 61
Agent	Fax.: 0041 (0)33 654 81 61
	e-mail info@colasit.ch
see front page	

Deposits on the impeller and soiling lead to imbalance and as a result to vibrations with undesirable side effects.  
If vibration occurs, switch the fan off immediately

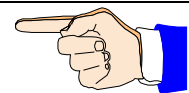

Contamination and encrustations should be removed with a soft tool without damaging the surface (e.g. with a wooden spatula or scraper). If possible, use water and a household cleaning agent

Solvents can corrode the material. These may only be used with the written consent of COLASIT.



To carry out cleaning work, we recommend the production of a process instruction

## 7 Spare parts

Please identify components by means of the position and drawing numbers as well as the order number and type designation.

Use only original spare parts. Our warranty becomes null and void if other or unapproved components are used.

Please address your spare parts order to our customer service department.

## 8 Operating instructions

To operate the fan, we recommend the production of process instructions. These documents are intended to simplify repetitive workflows, reduce the risk of incorrect operation and are a valuable aid for training and when personnel changes occur.

If the fan must be qualified, process instructions are an absolute prerequisite.

You will find important instructions on how to produce process instructions in various chapters of this operating manual.

To help ensure the safe operation of the fan, COLASIT offers the service of reviewing process instructions prepared by the operator

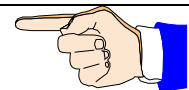

## 9 Logbook

For your own safety and as an aid to personal responsibility, we recommend the keeping of a logbook for the entire period during which the fan is in service.

All events should be recorded in the logbook.

In case of damage and also in case of an accident, this document is the first source of information.

For example, enter the date and your signature:

- Start and end of a work cycle
- Special events, even if they do not concern the fan itself (e.g. power failure, alarm)
- Change of supervision staff (e.g. in case of shift operation),
- Repairs carried out and spare parts installed,
- Putting out of operation,
- Special instructions,
- etc.

## 10 Disposal

Before disposing of plastics and other components (complete or as broken parts), please clean them as necessary to avoid any danger to the environment.

Dispose of the components properly. Instruct a waste disposal company to do this or return them to us for disposal.

## 11 Troubleshooting

If faults occur, we recommend you identify and clear them using the following table.

If the fault cannot be cleared, please contact our customer service department.

Fault	Possible causes	Remedy
Fan not running smoothly	Impeller imbalance	Rebalance by specialist company
	Impeller caked up	Clean carefully rebalance if necessary
	Material corrosion on impeller due to aggressive conveyed medium.	Consult the manufacturer
	Impeller deformed due to high temperature.	Consult the manufacturer. Install new impeller. Check bearings
	V-belt drive not correctly aligned.	Adjust belt drive
V-belt torn or damaged	Normal wear and tear	Replace V-belts in sets
	V-belt pretensioned too strongly	Tension replacement belt to manufacturer's specifications
V-belts slip due to	Incorrect pretension	Check belt tension and retighten if necessary
	Foreign bodies or soiling in grooves or pulleys	Clean pulleys and check belt profile
Leak at shaft bushing	Seal not suitable for application	Consult the manufacturer
Leak on sleeves	Sleeves defective	Replace sleeves
	Tensioning straps not tight enough	Retighten tensioning straps
Fan output too low	Incorrect rotation direction of impeller	Change rotation direction
	Pressure losses in ducts too high	Change duct arrangement
	Restrictors not or only partly open	Check opening on site

Fault	Possible causes	Remedy
	Intake or pressure duct blocked	Remove blockage
Fan fails to reach its rated speed	Electrical switching mechanisms incorrectly adjusted	Check motor protection setting and reset if necessary
	Motor winding defective	Please consult the manufacturer
	Drive motor drive not correctly designed	Please consult manufacturer to verify starting torque
Grinding noises when fan is running or starting	Intake duct fitted under tension	Remove intake duct and realign
Rise in temperature of roller bearings	Bearing was not greased	Change bearing and grease at regular intervals as stipulated in the maintenance instructions
	Bearing was excessively greased	Change bearing, otherwise as above
	Dust in bearing	Renew seal

## 12 Retrofittable original accessories

If not already a part of our scope of supply, these original parts are available ex stock when ordered.

- Sleeve round with fixing bands, stainless
- Sleeve round with flange on one side with fixing bands
- Sleeve rectangular with flanges on both sides
- Condensate drains
- Vibration dampers
- Splinter protection
- Lip seal
- Weather-proof motor cover for outside installation
- Inspection hole
- Frequency converters

## 13 Fan identification

The following rating plate is affixed to each COLASIT fan:

- 1 Manufacturer
- 2 Field for CE marking and applicable standards
- 3 ATEX-identification, for details see the section on Explosion Protection
- 4 Fan specifications: fan type, casing design, material of casing and impeller, order number and date of manufacture.
- 5 Technical specifications

## Part 2: Units

### 14 Design and function of the CMHV 900-1250

All impellers in this series are balanced to better than Q6.3 according to VDI 2060. The casing with its thermoplastic rear panel is screwed onto the support base and can be easily dismantled for inspection or cleaning purposes.

The fans are available in 2 standard designs

- Direct drive
- V-belt drive

As a basic principle, plastic fans are to be installed on the intake side in order to avoid leaks.

## 15 Dimensional drawings

### 15.1 Dimensions of the CMHV 900-1250 with direct drive

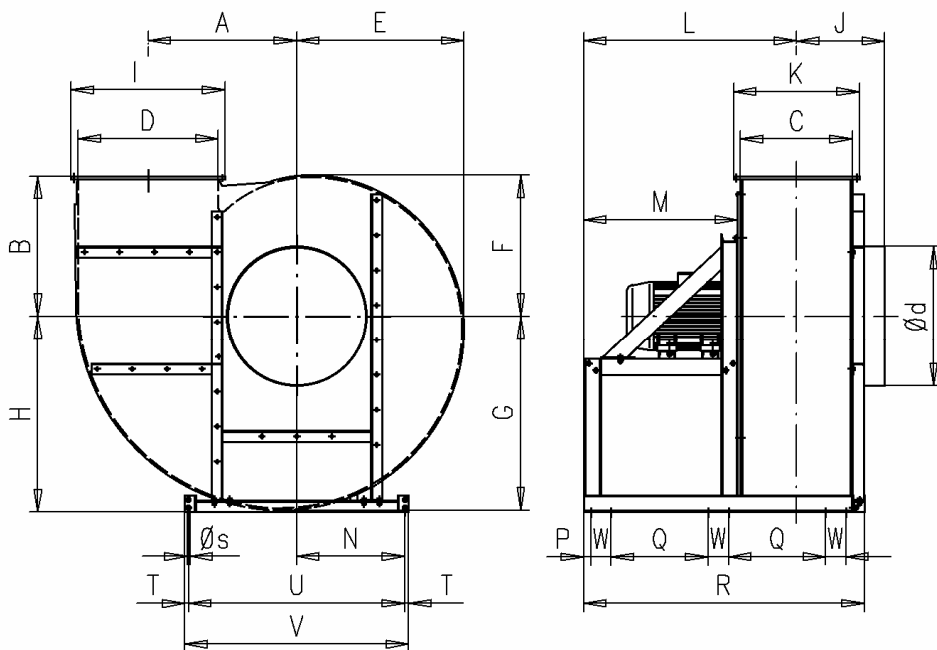

CMHV	900	1000	1120	1250
A	964	1062	1200	1265
B	900	1000	1120	1120
C	710	800	900	1000
D	900	1000	1120	1250
Ød	900	1000	1120	1250
E	1081	1197	1347	1405
F	907	1007	1133	1155
G	1255	1387	1561	1655
H 0°	1250	1400	1600	1800
H 45°	1250	1400	1600	1600
H 90°	1250	1250	1400	1400
H 135°	1250	1250	1250	1400
H 270°	1600	1800	2100	2100
H 315°	1400	1600	1800	1800
I	1000	1100	1220	1350
J	560	630	710	800
K	810	900	1000	1100
L	1475	1520	1570	1620
M	1100	1100	1100	1100
N	772	772	772	772
P	50	50	50	50
Q	648	693	743	793
R	1915	2005	2105	2205
Øs	12	12	12	12
T	27.5	27.5	27.5	27.5
U	1545	1545	1545	1545
V	1600	1600	1600	1600
W	146	146	146	146

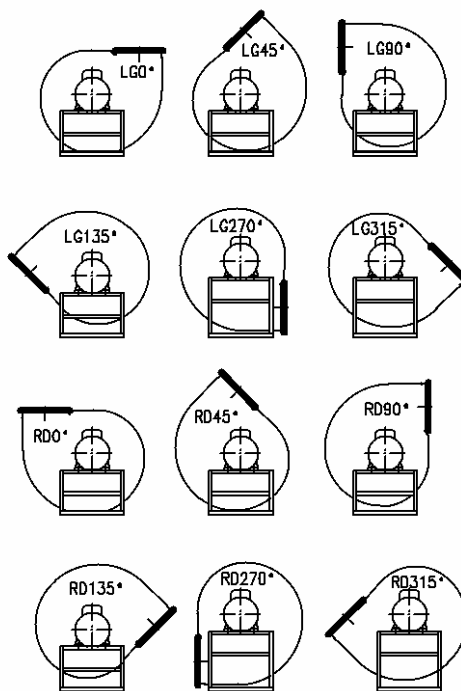

## 15.2 Dimensions of the CMHV 900-1250 with V-belt drive

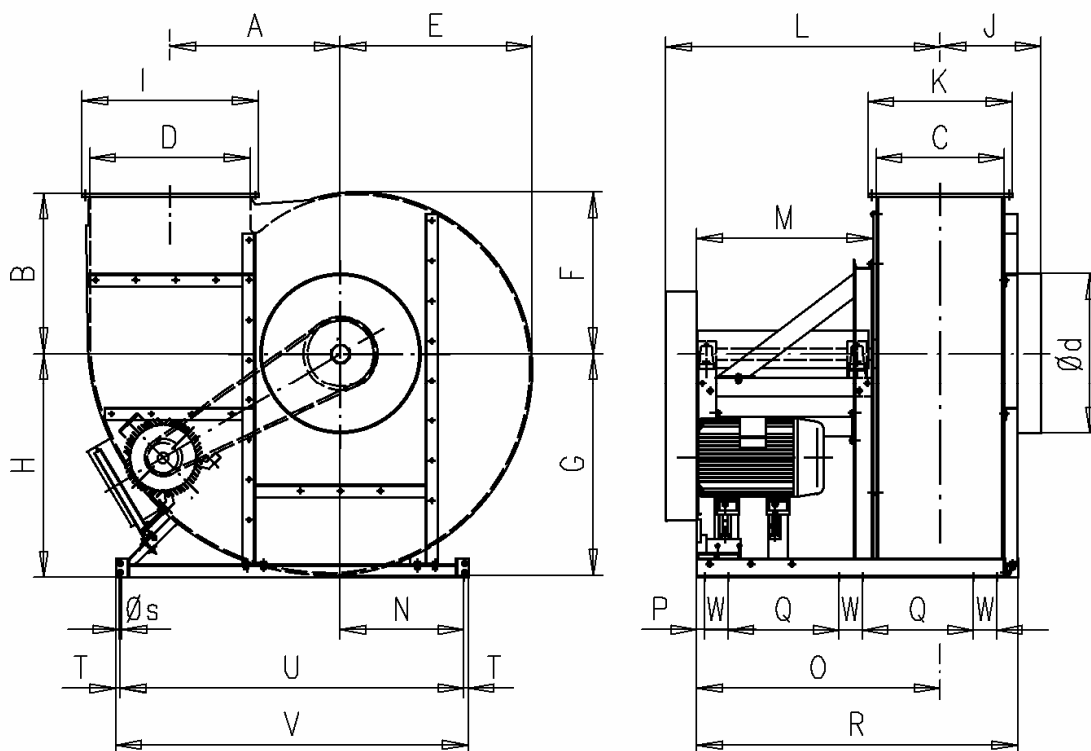

CMHV	900	1000	1120	1250
A	964	1062	1200	1265
B	900	1000	1120	1120
C	710	800	900	1000
D	900	1000	1120	1250
Ød	900	1000	1120	1250
E	1081	1197	1347	1405
F	907	1007	1133	1155
G	1255	1387	1561	1655
H 0°	1250	1400	1600	1800
H 45°	1250	1400	1600	1600
H 90°	1250	1250	1400	1400
H 135°	1250	1250	1250	1400
H 270°	1600	1800	2100	2100
H 315°	1400	1600	1800	1800
I	1000	1100	1220	1350
J	560	630	710	800
K	810	900	1000	1100
L	1665	1710	1760	1810
M	1100	1100	1100	1100
N	772	772	772	772
O	1475	1520	1570	1620
P	50	50	50	50
Q	648	693	743	793
R	1915	2005	2105	2205
Øs	12	12	12	12
T	27.5	27.5	27.5	27.5
U	2145	2145	2145	2145
V	2200	2200	2200	2200
W	146	146	146	146

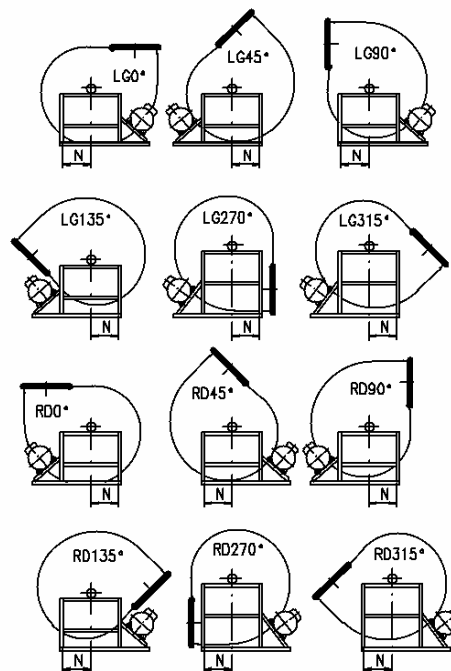

## 16 Assembly instructions

### 16.1 Assembly instructions CMHV 900–1250 with direct drive

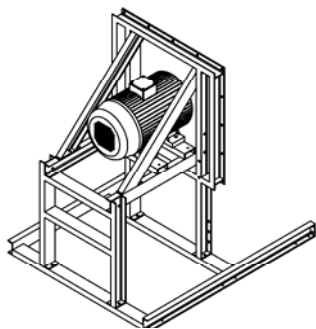

1. Screw individual parts of fan support together.  
Fit motor on support.

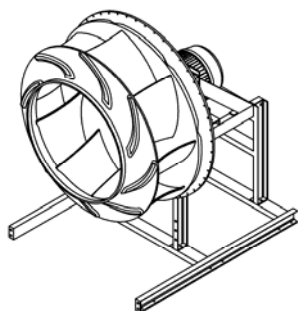

2. Fit rear panel to support. Slide impeller onto shaft.

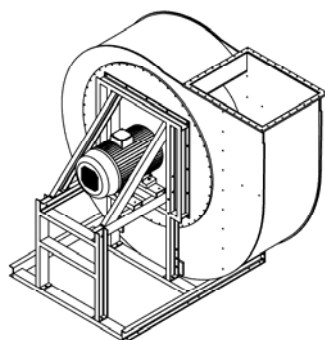

3. Screw housing to rear panel.

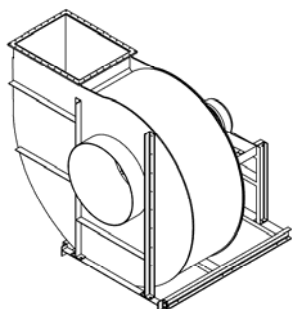

4. Screw bracket to base frame.  
Fit housing brace at front and rear. Position impeller, tighten and fit hub cap.

Dismantling in the same way but in reverse order

## 16.2 Assembly instructions for CMHV 900–1250 with V-belt drive

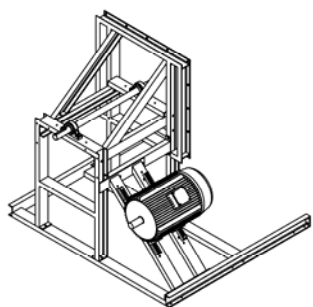

1. Screw individual parts of fan support together. Fit bearing units and shaft on support. Fix motor to support.

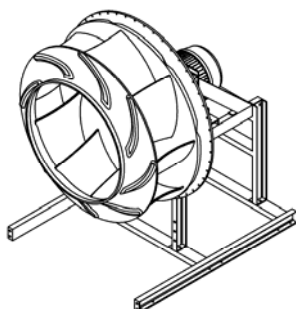

2. Fit rear panel to support. Slide impeller on drive shaft.

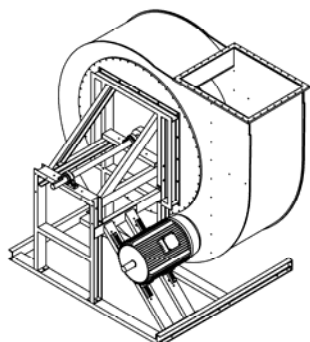

3. Screw housing to fan rear panel.

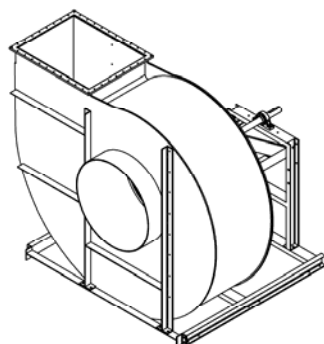

4. Screw bracket to base frame. Fit housing brace at front and rear. Position impeller, tighten and fit hub cap.

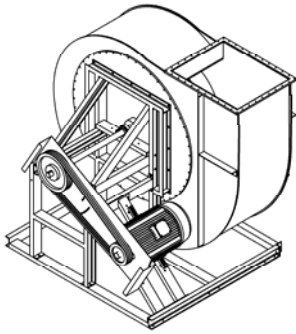

5. Fit V-belt protection panel and V-belt drive.

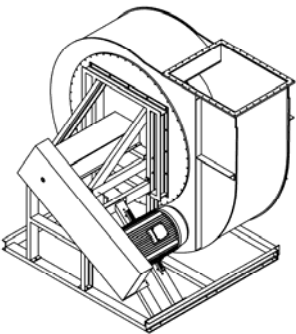

6. Mount V-belt and shaft protection.

Dismantling in the same way but in reverse order

## 17 Spare parts lists

### 17.1 Spare parts list for CMHV 900-1250 with direct drive

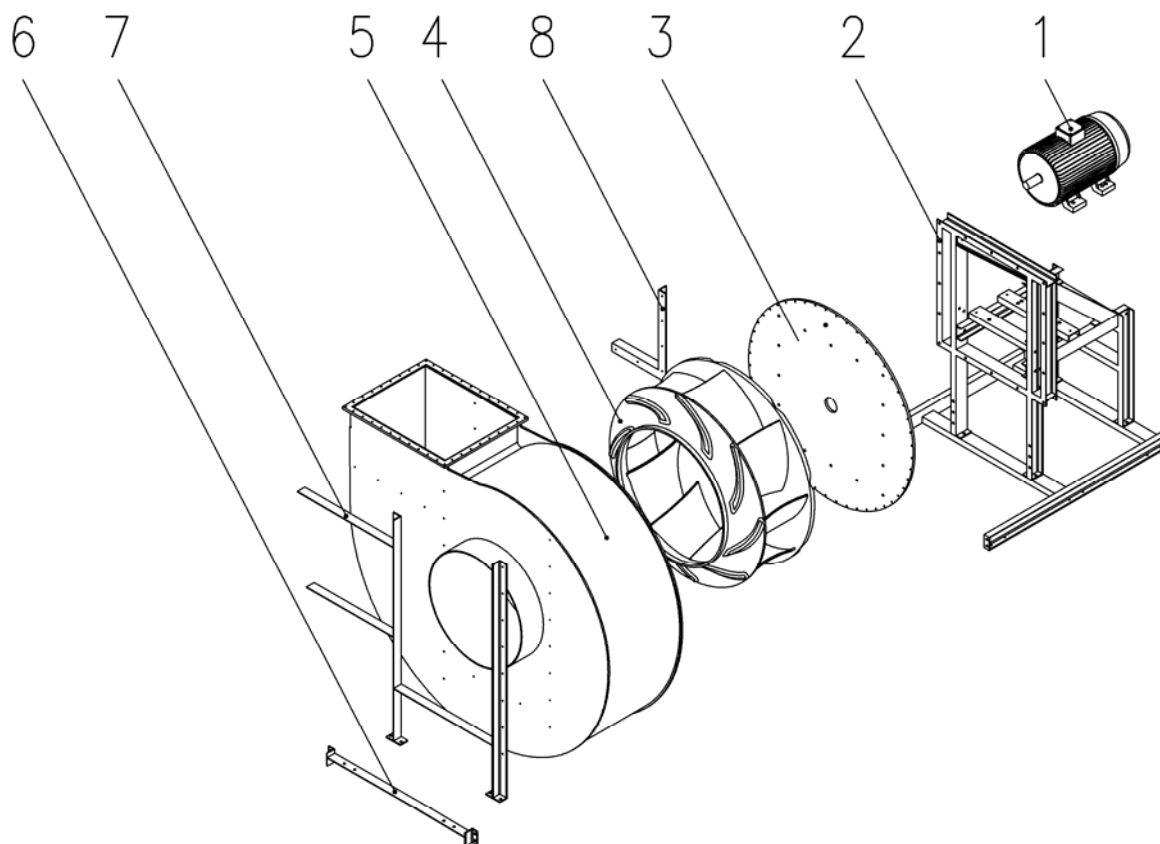

- 1 Base frame
- 2 Support construction
- 3 Motor plate and hub cap
- 4 Motor
- 5 Front steel plate
- 6 Round steel plate
- 7 Back plate
- 8 Impeller with Taper-Lock bushing
- 9 Casing
- 10 Support bracket

## 17.2 Spare parts list for CMHV 900-1250 with V-belt drive

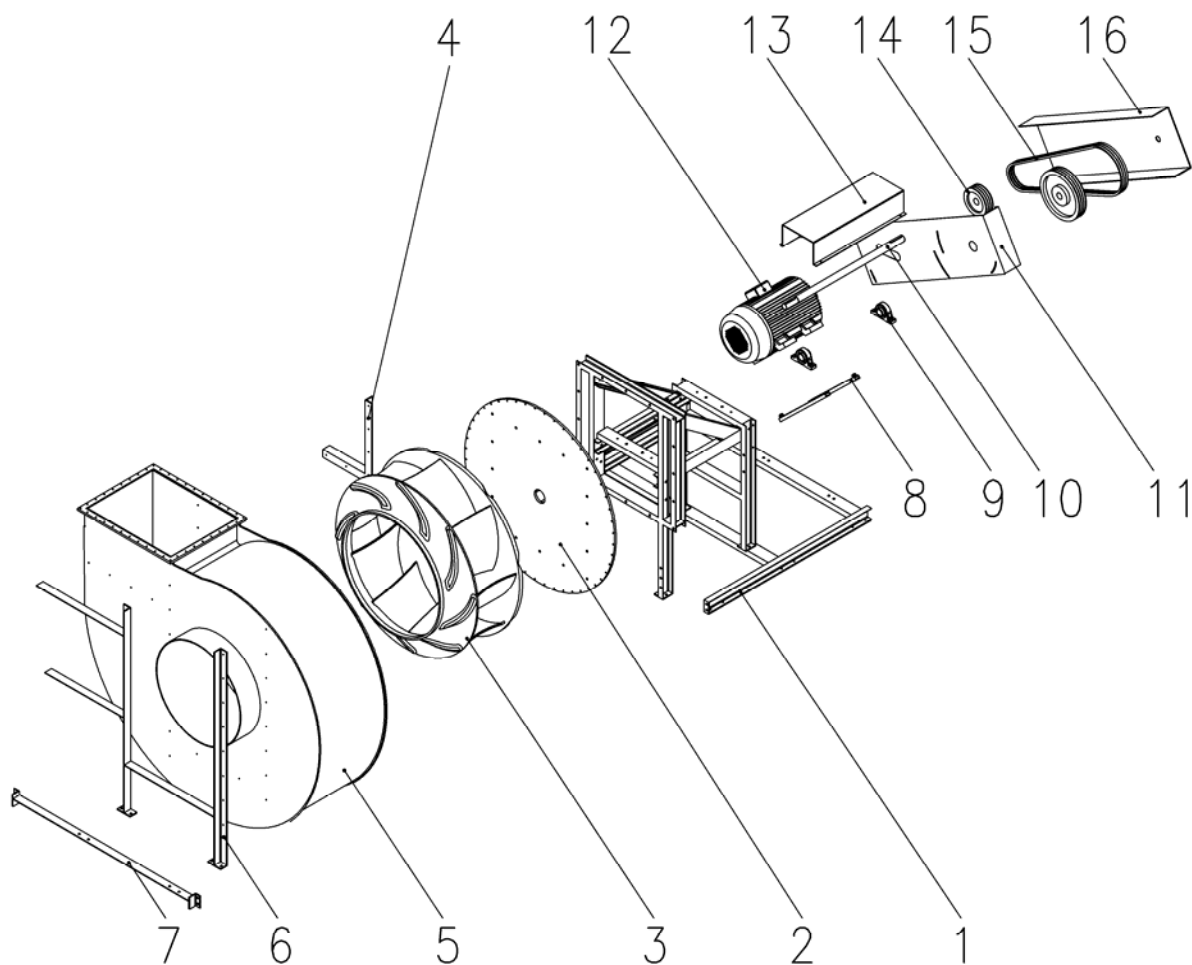

1	Support	11	V-belt protection steel plate
2	Rear panel	12	Motor
3	Impeller	13	Shaft protection
4	Casing reinforcement back	14	V-belt pulley complete
5	Casing	15	V-belt
6	Casing reinforcement front	16	V-belt protection
7	Support bracket		
8	Sliding rails		
9	Pedestal bearing unit		
10	Shaft		

## Part 3: Certification

### 18 Certifications

#### 18.1 CE Manufacturer's declaration

**EG-Konformitätserklärung**  
CE Déclaration de conformité  
EC Declaration of conformity

Wir  
Nous  
We

COLASIT AG  
Postfach 85  
CH-3700 Spiez

erklären in alleiniger Verantwortung, dass das Produkt  
déclarons de notre seule responsabilité que le produit  
bearing sole responsibility, hereby declare that the product

**Kunststoff-Industrieventilator**  
**Ventilateur industriel en plastique**  
**Plastic industrial fan**  
**CMHV 900-1250**

auf das sich diese Erklärung bezieht, mit der/den folgenden Norm(en) oder normativen  
Dokumenten übereinstimmt:

auquel se rapporte la présente déclaration est conforme aux normes ou aux documents normatifs  
suivants:

referred to by this declaration is in conformity with the following standards or normative documents:

Bestimmungen der Richtlinie Désignation de la directive Provisions of the directive	Titel und/oder Nummer sowie Ausgabedatum der Norm(en): Titre et/ou numéro ainsi que date d'émission de la/des norme(s): Title and/or number and date of issue of the standard(s):
2006/42/EG: Maschinensicherheit 2006/42/CE: Sécurité des machines 2006/42/EC: Machinery safety	EN ISO 12100-1: 2004 EN ISO 12100-2: 2004 EN ISO 14121-1: 2007 EN ISO 13857: 2008 EN 60204-1: 2006
2004/108/EG: Elektromagnetische Verträglichkeit 2004/108/CE: Compatibilité électromagnétique 2004/108/EC: Electromagnetic compatibility	EN 61000-6-2: 2005
Name und Adresse des Dokumentationsverantwortlichen: Nom et adresse de la personne responsable de la documentation: Name and address of the person authorised to compile the relevant technical documentation:	Andreas Roth COLASIT AG Faulenbachweg 63 CH-3700 Spiez

Spiez, 19.07.2011



U. Moser (Leiter Technik/Responsable dép. technique/Chief technical officer)

## 18.2 Further certificates

This operating manual has the following certificates enclosed:

- Design datasheets for the fan